

COLOR  
COMPUTER  
SECRETS  
REVEALED

*Paul G. Lewis*

Published by Disk 'n Data -- all rights reserved.

---

\* TRS-80 is a trademark of the Tandy Corporation.

## APPENDIX 1 - UTILITY PROGRAMS

Outlined in this appendix are three utility programs which you might find of interest.

Included are a printer driver which helps overcome the inherent limitations of certain printers (ie. no carriage return with a linefeed), a program to limit the width of printer lines and one which will display the full alpha-numeric and block graphics capability of the computer.

In each case, key in the program as indicated (the REMarks statements do not need to be typed in) and follow the instructions included as part of the remarks.

```
5 REM THIS PROGRAM ILLUSTRATES THE MEMORY MAPPED DISPLAY
6 *OF THE COLOR COMPUTER BY GENERATING THE COMPUTER'S
7 *ENTIRE CHARACTER SET
10 POKE 65495,0:'SPEED UP MICROPROCESSOR
20 CLS
30 *START AT TOP LEFT HAND CORNER AND END AT BOTTOM RIGHT HAND CORNE
35 FOR X=1024 TO 1535
40 C=C+1:'COLOR COMPUTER CHARACTER SET FROM CHR$(0) TO CHR$(255)
50 IF C=256 THEN C=0
60 POKE X,C
70 NEXT X
80 GOTO 80
```

Copyright (C) Disk 'n Data, 1982

First printing -- August, 1982

Second printing (revised) -- November, 1982

Third printing -- January, 1983

Fourth printing (revised) -- March, 1983

This publication is copyright in its entirety by Disk 'n Data, 5450 Rugby Street, Burnaby, B.C., Canada V5E 2N1. All rights are reserved.

None of the text in this publication, the illustrations it contains, or any part thereof, may be reproduced or transmitted in any form or by any means, be they manual, electronic or mechanical, including but not limited to photocopying, recording, storage in an information retrieval system or otherwise without prior permission in writing from the publisher.

While Disk 'n Data has made every effort possible to ensure the accuracy of the information contained in this publication, the publisher in no way guarantees the accuracy of this information nor in any way assumes any liability arising out of the use of, or application of, this information.

PRINTED IN CANADA

## CONTENTS

1-	INTRODUCTION .....	4
2-	HOW IT WORKS - THE PRIMARY COMPONENTS ...	5
3-	THE MEMORY MAP .....	8
4-	CENTRAL PROCESSING UNIT .....	13
5-	SYNCHRONOUS ADDRESS MULTIPLEXER .....	14
6-	THE SPEED UP POKE MYTH .....	19
7-	PERIPHERAL INTERFACE ADAPTERS .....	21
	Merging BASIC programs .....	23
8-	DEALING WITH PRINTERS .....	26
9-	READ ONLY MEMORY .....	31
	Color BASIC 1.0 and 1.1 .....	32
10-	TAKING A LOOK INSIDE .....	33
	Chips inside the R.F. shield .....	35
	Chip index notch and pin numbering ...	35
	Taking a look around .....	37
11-	CLEARING MORE MEMORY .....	39
12-	16K UPGRADE .....	42
13-	32K UPGRADE .....	45
	The piggyback upgrade .....	45
14-	E-SERIES 32/64K UPGRADE .....	50
	Jumpers for the E-series computer ...	52
	Accessing the other 32K .....	55
	The 64K modification .....	55
15-	CSAVING MACHINE LANGUAGE PROGRAMS .....	58
16-	SOME LAST POKES .....	59
	APPENDIX 1 - UTILITY PROGRAMS .....	62

## 1 - INTRODUCTION

Much has been said and written about the Color Computer. However, most of this information has been directed either towards the beginner or the experienced assembly / machine language programmer. This book is written for that in-between group, the average computer user.

COLOR COMPUTER SECRETS REVEALED contains a wealth of information on the workings of this incredible machine. However, it assumes a fundamental knowledge of BASIC programming as contained in GETTING STARTED WITH COLOR BASIC (which accompanies the computer) and is not designed as a BASIC programming tutorial. On the other hand, neither is it an instruction manual for the assembly language programmer.

In compiling this book, every effort has been made to devise programs which will run on all types of Color Computers - be they 4K, 16K or 32K, regular or Extended BASIC. However certain commands, such as PEEKing, cannot be carried out without Extended BASIC.

Throughout the course of this book you will learn about the various major components which comprise the Color Computer. You will learn how to upgrade these components, and how, through the use of PEEK and POKE commands, to make your computer do many things heretofore thought impossible.

Read on, and enjoy.

DISK 'N DATA

## 2 - HOW IT WORKS: THE PRIMARY COMPONENTS

Like all of its contemporary brothers and sisters, from the tiniest electronic calculator to the largest mainframe computer, the Color Computer is composed of a series of Large Scale Integrated circuit or LSI chips.

However, it's here that all comparison begins and ends. The only similarity between the Color Computer and its predecessor, the original TRS-80 Model I, are the initials.

At the heart of the Color Computer beats a Motorola 6809E chip.

This microprocessor, an updated version of the legendary 6800 family, is far superior to the Z-80 used in the Model I. It is one of the fastest and probably the most powerful 8-bit microprocessor available today. In fact, it's really more than just an 8-bit microprocessor as it has 16-bit addressing capability -- but more on that later.

In addition to the 6809 Central Processing Unit or CPU, just four other major chips are required for most functions of the Color Computer. These are the Synchronous Address Multiplexer (SAM), the Video Display Generator (VDG) and two Peripheral Interface Adaptors (PIAs). When supported by Read/Write Memory (RAM) and the BASIC Read Only Memory (ROM), a regulated power supply and appropriate input/output devices (ie. keyboard, cassette recorder, television monitor, etc.) these are all that are basically required to run the computer.

The function of each major component will be the subject of future chapters of this book, but in order to achieve an overall understanding of how the Color Computer works, let's examine each briefly in turn:

**CENTRAL PROCESSING UNIT** - The 6809E microprocessor is the principle controlling device in the computer. The E suffix indicates that the particular version used in the Color Computer does not have in-built clock circuitry -- this function is provided by the Synchronous Address Multiplexer (see below).

The primary function of the CPU is to provide or to request data and to select the proper address for storage of this data. It accomplishes this by controlling the flow of information to and from the various internal components in the computer, to and from the computer's input and output devices.

Additionally, the 6809 is also capable of providing a limited number of mathematical and logical manipulations to the data it controls.

The CPU, in turn, is controlled by the preprogrammed instruction set stored in the BASIC ROM. Without these instructions the CPU would operate randomly, out of control, executing instruction after instruction without rhyme or reason.

**SYNCHRONOUS ADDRESS MULTIPLEXER (SAM)** - The Synchronous Address Multiplexer or SAM in many ways acts as the band leader of the Color Computer. In addition to providing the clock system which is used to co-ordinate timing of all the various functions of the computer, the SAM chip orchestrates the flow of information to and from the RAMs. It provides refresh to the RAMs and controls address multiplexing. By varying the pin connections, the SAM can be made to work with either 4, 16 or 64K dynamic RAM chips (see the chapters on upgrading your computer).

**VIDEO DISPLAY GENERATOR (VDG)** - As the name implies, it is the VDG which allows you to monitor the Color Computer via your television screen. It generates and displays the character and graphics sets in their various modes. The VDG is thus responsible for several of the characteristics of the Color Computer that are most frequently criticized -- the inverse lower case characters, the 32x16 character display and the mask which borders the screen.

The VDG obtains the information it is to display from the RAMs - which in turn are controlled by the SAM chip.

**PERIPHERAL INTERFACE ADAPTERS (PIAs)** - The two Peripheral Interface Adapters in the Color Computer control which of the input/output devices will be employed for accessing or displaying data to or from the computer. It is the PIAs, for example, which allow you to output information to the T.V. screen (PRINT) or the printer (PRINT#-1), read the keyboard (INKEY\$) or seek inputs from the joysticks.

**READ/WRITE MEMORY (RAM)** - The Read/Write Memory (often incorrectly referred to as Random Access Memory) or RAM is that

area of the computer which is used for storage of data and/or instructional sequences. The dynamic memory of the Color Computer requires constant refresh in order not to lose the data it contains. Interruption of this function (which is provided by the SAM), such as turning off the power, will result in a partial or total loss of the data stored in the RAMs.

The Color Computer is designed to operate with any one of three types of dynamic RAM chips (depending on board configuration and programming of the SAM chip -- see memory upgrading chapters for details) -- 4060s (4K x 1), 4116s (16K x 1) or 4164s (64K x 1).

READ ONLY MEMORY (ROM) - Unlike RAM, Read Only Memory chips do not require refresh and retain their stored data regardless of power interruptions or the like. The data they contain has been permanently burned in and cannot be altered.

It is the ROMs which control the actions of the CPU through a programmed instruction set. On "power up" the CPU jumps to the start address of ROM and performs the initialization and reset operations stored there, before seeking input from the keyboard.

Two versions of the basic ROM are currently available for the Color Computer (with a third to be available shortly). These are COLOR BASIC 1.0 and COLOR BASIC 1.1, both programmed by Microsoft, of Bellevue, Wash. To these may be added a secondary instruction set, EXTENDED COLOR BASIC 1.0 (with, we understand, version 1.1 presently in the making), also by Microsoft. All the ROMs are 68A364 chips.



### 3 - THE MEMORY MAP

In order to become familiar with how the Color Computer operates, it is important to become acquainted with the Color Computer's memory map. The memory map is a breakdown of all the computer's addresses (more than 65,000 of them in the case of the Color Computer), detailing where predetermined operations will take place.

Unlike its earlier brother, the Model I, the Color Computer has been designed so that User RAM is located at the bottom of the memory map, and the operating system ROM (Color BASIC, Extended Color BASIC, Disk BASIC and cartridge ROM) is placed at the top.

In block form, the memory map looks as follows:

ADDRESS (DECIMAL)	CONTENTS
0000 - 4095	Initial 4K of RAM
0000 - 16383	16K RAM
0000 - 32767	32K RAM
32768 - 40959	Extended Color BASIC
40960 - 49151	Color BASIC
49152 - 65279	Disk BASIC
49152 - 65279	Cartridge ROM
65280 - 65535	Input/Output

The Color Computer's display is also memory mapped. That is to say, the video display is stored in the actual working memory (RAM) of the computer.

If you want to write anything to the Color Computer's video display, all you have to do is to store the character you wish displayed into the appropriate area of the Color Computer's memory.

Normally, the Color Computer's display is at addresses 1024 to 1535. To see how this works, try typing in the following:

```
POKE 1263,32
```

You should get a black square in the centre of your video display.

Now try:

```
POKE 1263,65
```

The black square will be replaced by the letter "A" in the centre of your screen.

Try experimenting with other characters (0 to 255) at POKEs between 1024 and 1535 to see how you can vary the display information.

Appendix I - Utility Programs, has a short routine which will fill your screen with the entire Color Computer character and block graphics set.

That's all very fine -- you can see addresses 1024 to 1535 on the screen, but what if you want to see what's located elsewhere in the other 32000 RAM address locations?

By whispering the right secret message to the SAM (Synchronous Address Multiplexer, remember?) you can page through memory like thumbing through a book.

Try running the following program:

```
10 POKE 65479,0:GOTO 10
```

You are now displaying the second alpha-numeric page, located between addresses 1536 to 2047 inclusive.

Don't believe me? Then try running the following:

```
10 POKE 65479,0
20 FOR X=1536 TO 2047
30 POKE X,65
40 NEXT X
50 GOTO 50
```

Your computer will switch to page two, and gradually fill the screen with letter "A"s to show that it is, in fact, displaying those addresses.

Similarly, try the following:

```
10 POKE 65480,0:POKE 65483,0:GOTO 10
```

You are now displaying memory locations decimal 2048 to 2559 inclusive (page 3).

If you want to experiment some more, see the chapter on the Synchronous Multiplex Addresser -- Display Offset -- for further information.

The alpha-numeric display is located as follows:

<u>ADDRESS (DECIMAL)</u>	<u>ALPHA-NUMERIC "PAGE" NO.</u>
1024 - 1535	1
1536 - 2047	2
2048 - 2559	3
2560 - 3071	4
3072 - 3585	5
etc., etc.	6 - 63
32256 - 32768	64

As you can see, each alpha-numeric page occupies exactly 512 bytes or 0.5K of user RAM. Thus, you can, if you wish, display up to 64 different pages of video information (if you have 32K RAM installed).

High resolution graphics memory, on the other hand, requires 1536 bytes or 1.5K of memory, and its display too, is memory mapped.

The hi-res graphics memory is as follows:

<u>DECIMAL ADDRESS</u>	<u>GRAPHICS PAGE</u>
1536 - 3071	1
3072 - 4607	2
4608 - 6143	3
6144 - 7679	4
7680 - 9215	5
etc., etc.	

You can flip through the graphics pages as you can the alpha-numeric pages. Extended Color BASIC has made this easy with the PMODE function. For example, PMODE 4,1 tells the computer that you wish to use graphics resolution 4 (hi-res.) on page 1.

On power-up, the computer arbitrarily sets aside certain locations in RAM for certain display functions. For example, it sets up the initial video display as addresses 1024 to 1535

inclusive. It also reserves four pages for use with graphics (pages 1 to 4 or 1536 to 7679 RAM). This is why you need at least 16K for Extended BASIC, and why, on power-up, you get such a low PRINT MEMORY value. All the reset of RAM has been reserved (see chapter on Clearing More Memory on how to get back most of this reserved memory).

That explains what occurs above address 1024 -- but what's happened with the first 1023 bytes of RAM?

Let's page to that area, and see what's happening. Run the following:

```
10 POKE 65480,0:GOTO 10
```

Interesting, isn't it?

What you're viewing is the initial 512 bytes of RAM from decimal address 0000 to 512. And what you see on the screen is the heart of your Color Computer beating away.

The Color Computer has set aside this area for systems use. It uses it to store clock information, pointers and all the other exciting stuff which makes your computer tick.

Here's a brief description of some of the things you're seeing:

Count over 11 characters from the left on the top row. You should see, (depending on the type and RAM size of the Color Computer you have) the letter "A" at that point, followed by a graphics block and another letter "A". These are decimal addresses 11 and 13, and the As are the string buffer pointers.

The rapidly flashing halfmoon type object you see a little further in that line is address 25 -- it denotes the start of your BASIC program.

The blinking boxes you see on the second and third and fourth lines are related to system timing.

The area beside the U on the fourth line shows the top of user RAM (address 116).

The speedily changing block on the sixth line is a routine which checks for the next input character from BASIC.

On line 9, you should see another quickly flashing box. This is the area where the current value of the timer is stored. A few characters to the right is the upper/lower case flag. Hold the <SHIFT> and the 0 keys down together and watch this flag change.

Two lines below where the current timer value is stored -- that

large buff colored area -- is the keyboard buffer. Run your fingers over the keyboard and see how each key is represented here.

On the bottom rows of this page, if you have recently CLOAded or CSAVEd a program, those programs names should be displayed here.

Now try this:

```
10 POKE 65479,0:POKE 65480,0:GOTO 10
```

Now you're viewing RAM between addresses decimal 512 and 1023. This area, too, is used by the Color Computer as a temporary systems scratch pad. On it you should see the current BASIC line the computer is executing.

Certain parts of this reserved area may be accessed by the user, in order to maximize the amount of RAM space available (see chapter on Clearing More Memory for details).

So there you have it -- all 65535 (up to 32K of user RAM and up to 32K of ROM and system control for a total of 64K of memory) addresses of your Color Computer are accounted for.

#### 4 - CENTRAL PROCESSING UNIT

The Color Computer's 6809E Central Processing Unit is the current state-of-the-art 8-bit microprocessor. It is faster in many operations than both the Z-80, which is used in such computers as the TRS-80 Model I, and the 6800 (Apple, PET, etc.). In fact few, if any 8 bit microprocessors can match the speed and sophistication of the 6809.

Like all the major components; the 6809 CPU used in the Color Computer was designed and built by Motorola Inc. Incidentally, for those of you with a more technical bent, Motorola has spec. sheets available on the 6809 as well as all the other major chips in the Color Computer. These spec. sheets are usually available free for the asking. Enquire at your local electronics components store or write Motorola Semiconductor Products Inc., 3501 Ed Bluestein Blvd., Austin, Texas 78721 for details.

Unlike most 8-bit systems, the 6809 uses several 16-bit operations, which results in extremely fast operation. The 6809 has two 16-bit index registers, two 16-bit indexable stack pointers and two 8-bit accumulators which can be concatenated to form one 16-bit accumulator.

As mentioned earlier, the E series 6809 used in the Color Computer has no on-board clock system -- it relies on the Synchronous Address Multiplexer (SAM) for timing functions.

The 6809 includes 6800 instructions as a subset, in assembly language programming. Supplementing this are powerful branching, indexing and stacking operations.

The 6809 is not directly accessible through BASIC, and thus a more indepth discussion is somewhat beyond the scope of this book. Therefore, let's skip ahead to the SAM, which is easily programmable, and which in turn is capable of programming many of the 6809's functions.

## 5 - SYNCHRONOUS ADDRESS MULTIPLEXER

The most important support chip in the Color Computer is the 74LS783 Synchronous Address Multiplexer, affectionately known to its friends as SAM.

Occupying position U10 on the printed circuit board, this versatile chip functions primarily as a dynamic memory controller, but also provides vital roles in the operation of peripherals and in video display.

As was discussed in the last chapter, the 6809 microprocessor used in the Color Computer does not have an on-board clock system. This function is provided by the SAM, which has not one but two clock signals -- E and Q.

It is the job of the SAM, as well, to allow the CPU to utilize the full amount of available RAM, as well as to provide constant refresh to that RAM.

Among its other diverse functions are control of the two Peripheral Interface Adaptors, and synchronization of the video display.

All these functions are programmed into the SAM via its 16-bit control register, located at the very top of the memory map between addresses 65280 and 65535 (decimal). The register is allocated as follows:

VDG Addressing Mode	- 3 bits
VDG Address Offset	- 7 bits
Page Switch	- 1 bit
MPU Rate	- 2 bits
Memory Size	- 2 bits
Map Type	- 1 bit

Each of these bits is software programmable. To set any bit merely POKE any value (0 is probably the most convenient value to use) into the appropriate odd-numbered address between decimal 65472 and 65503 (HEX \$FFC0 to \$FFDF). Similarly, to clear any of these bits, POKE any value into the appropriate even-numbered addresses in this range.

Note that the data written during this process is unimportant - all that is required to set or clear any of the 16 bits is to write any data into the appropriate address.

At power-up, each bit is cleared.

Let us look at each one of these bits in some detail, and examine how they can be programmed.

#### VDB ADDRESSING MODE (65472 - 65477)

Three bits located between addresses 65472 and 65477 (decimal) are used to tell the SAM the current display mode of the VDB. This is necessary because it is the SAM which controls the sharing of RAM between the CPU and the VDB (remember the VDB visually depicts locations in RAM).

Improper co-ordination between the SAM and the VDB usually results in a garbage display (although cross-programming does work in a few modes).

At power-up the three bits in this mode are cleared. That is done by writing any data to addresses 65472, 65474 and 65476. This default setting is the normal alpha-numeric mode.

Writing any data into address 65473 places you in PMODE 1. Similarly, writing any data into addresses 65473 and 65475 places you in PMODE 2, etc.

#### DISPLAY OFFSET (65478 - 65491)

This area of SAM allows you to page through memory and visually display on your television monitor the data that is stored there, as you did earlier in the Memory Map chapter.

On power up, the default setting is to clear the even numbered bits 65478 to 65490 inclusively.

This provides you with the normal visual display -- that is between addresses decimal 1024 to 1535.

Writing any value into address 65479 pages you through memory, and displays addresses decimal 1536 to 2047 on the screen.

To display the next page (addresses from decimal 2048 to 2559), POKE any value into addresses 65480 and 65483.



Similarly, the next page (decimal 2560 to 3071) can be called up by POKEing any value into addresses 65479, 65480 and 65483, etc. (note the use of binary). In this manner, all 32K of user RAM (if installed) may be called up and displayed on the screen.

Note.-- in order for you to be able to observe the display, try the short programs as follows:

```
10 REM THIS WILL DISPLAY ADDRESSES 1024 TO 1535
20 POKE 65478,0:POKE 65490, 0
30 GOTO 30
```

```
10 REM THIS WILL DISPLAY ADDRESSES 2560 TO 3071
20 POKE 65479,0:POKE 65480,0:POKE 65483,0
30 GOTO 30
```

Have another look at the Memory Map chapter for more information.

#### PAGING FOR 64K RAM (65492 - 65493)

The SAM chip, as designed by Motorola, has provision for 64K of user RAM. However, Radio Shack, at present, has designed the Color Computer in such a manner that only 32K can be accessed directly (see the 32/64K Upgrade chapter for more information).

In theory, POKEing any value into address 65492 allows you to access the first 32K of memory, while POKEing any value into address 65493 allows you to access or page to the second 32K of RAM. However, this function does not, at present, appear to be supported in the Color Computer. The default (and as far as we have been able to determine the only setting which works) is to clear this bit (i.e. write anything into address 65492).

#### MPU CLOCK RATE (65494 - 65497)

As mentioned earlier, the SAM chip supplies the microprocessor with its vital time base, used to synchronize all its many and varied operations.

The SAM chip, in fact, provides two clock signals, E and Q which between them determine when to trigger various computer functions. Both these signals are derived from the master clock frequency of 14.31818 MHz.

This frequency is normally divided by 16 for a resultant clock frequency of 0.89 MHz. However, by setting (POKEing any value into) addresses 65495 and 65497, that frequency is divided by 8 rather than 16, effectively doubling the clock speed of the computer to 1.78 MHz. The result is that some computer functions can be operated at twice their normal speed (see the next chapter on the "Speed Up Poke Myth" for more information).

These addresses allow modification of the E and Q clock signals (for purists, the Q signal leads the E signal by 90 degrees). E is the most important of the two clock signals as it allows the multiplexing of RAM addresses. It also provides the timing for read and write cycles from the CPU, and synchronizes the use of RAM between the CPU and the VDB.

#### MEMORY SIZE (65498 - 65501)

---

At power up, it is necessary for the SAM chip to tell the CPU how much Read/Write memory (RAM) it has available. This is done by programming addresses 65498 to 65501, inclusively.

Clearing these two bits (writing data to 65498 and 65500) tells the CPU it has 4K dynamic RAM chips available. Setting the least significant of these bits (writing any data to 65499) tells the CPU it has 16K chips, and setting the most significant bit (writing any data to 65501) signifies 64K chips (even though only half or 32K of these chips are actually used in the Color Computer at present).

The various defaults (depending on which chips you have installed in your computer) are usually set with jumpers inside your computer (see the various Upgrade chapters for details) so that at power up the CPU knows exactly what it has to contend with.

#### MAP TYPE (65502 - 65503)

---

This final bit of the SAM register tells the computer which of two possible memory modes are presently configured -- all RAM or RAM + ROM.

As the Color Computer is a ROM-based system (with the BASIC, Extended BASIC and Disk BASIC operating systems all in ROM),

clearing this bit (writing any value to address 65502) is the only operation which is recognized at present (divides the memory map into RAM + ROM). Possibly in later versions of the Color Computer one will be able to select the other option at will (for more information see the 32/64K Upgrade chapter).

## 6 - THE SPEED UP POKE MYTH

If you've read any of the many journals devoted to the Color Computer, you've undoubtedly heard that there's a magical poke which will double the operating speed of your computer.

If you're lucky, typing POKE 65495,0 will make your computer operate faster (type POKE 65494,0 to return it to normal speed). Note the "if you're lucky..." part. It will not work with all Color Computers. Here's why...

As we mentioned in the last chapter, one of the 16 programmable bits of the SAM register is MPU rate. This clock rate selection is located between decimal addresses 65494 and 65497 inclusive.

The default setting for the Color Computer is clearing these two bits -- ie. writing any value into addresses 65494 and 65496. This results in the normal SAM clock frequency of 14.31818 MHz being divided by a factor of 16 for a resulting frequency rate (speed) of 0.89 MHz.

Setting the lower bit (POKE 65495,0) changes the frequency of the E and Q clock signals, depending on the address that is being written to. For example, if the CPU is doing internal arithmetic or outputting information (to the cassette or printer) it will do so at double its usual rate (it divides the clock frequency by 8 rather than 16). However dynamic memory refresh and video output are done at the normal rate (ie. clock signal divided by 16).

Setting the higher bit (POKE 65497,0) doubles all operations (ie. divides the clock signal by 8). This is accomplished by stealing the time normally used for VDB refresh. However, as a result, the video display loses its sync. and dynamic RAM refresh is not available.

If, when you type POKE 65495,0, your computer's cursor flashes at twice its normal speed, then your computer will work with the address-dependent speed up. This is fine for doing data processing or arithmetic work, however the PRINT#-2 (line printer) function and the CSAVE/CLOAD (cassette) functions will not work properly as their timing signals have been thrown out of whack. Any SOUND or PLAY instructions will also sound

funny -- and will be at a much higher than normal pitch.

Telling your computer to POKE 65497,0 , will almost certainly eliminate the video display (although in some cases this may be adjusted internally). You will notice immediate image degradation -- to the point where nothing is recognizable. Even if you manage to adjust the image sync. internally, using this POKE will preclude you from using all input/output functions -- including the keyboard, as all timing cycles have been altered. It is usable only for internal processing.

If your computer hangs up (ie. everything freezes on the screen -- no information can be inputted or outputted) then the reason is unfortunately simple. The Color Computer was really not designed to run at the higher speed.

There are three different types of 6809E microprocessors available -- the 6809E, the 68A09E and the 68B09E. Each is capable of operating at higher clock speeds. The Color Computer is equipped with a stock 6809E and not the more expensive 68B09E which will operate at the higher speed. However, some standard 6809Es will work at this speed, others just won't. In order to ensure that your Color Computer will operate at the high speed, you'll have to replace the 6809E with a 68B09E. You'll also have to replace the two 6821 PIAs with 68B21s.

A further problem are resistors R73 and R74 inserted between the CPU and the SAM chip. These resistors may have to be removed or replaced for the speed-up to work properly. Removing the resistors could allow a build-up of static electricity to damage either the CPU or the SAM (they were put in place to prevent such a static discharge).

Is it worth modifying your computer -- only you can decide.

However, be forewarned that when operating at double the speed some of the internal components -- especially the SAM and the CPU -- tend to operate very warm, and could, over time, burn out. If you use any of the speed-up pokes with any regularity, you'd be advised to purchase a couple of heat sinks for the SAM and the CPU chips. Stick these on with silicone heat grease and that should keep everything running cool (see chapter on Getting Inside the Color Computer for further details).

## 7 - PERIPHERAL INTERFACE ADAPTERS

All input/output functions of the Color Computer are regulated by two 6821 Peripheral Interface Adapters or PIAs.

The PIA at position U8 on the printed circuit board controls both the keyboard and the joystick ports, while the PIA at position U4 controls the cassette and RS-232 I/O.

It is the PIAs which regulate whether the various ports on the Color Computer will be inputting or outputting information (ie. will the cassette port be CLOADing or CSAVEing?). The PIAs, in turn, are regulated by the SAM chip.

Each PIA receives its particular configuration during the reset operation of the CPU.

Let's look at each one of these input/output (I/O) devices in turn:

### KEYBOARD

-----

The Color Computer uses a calculator style keyboard which outputs in ASCII readable format. Normally this keyboard is acceptable for everyday use -- in fact, in many instances, because of the short travel of the keys, it is somewhat faster than more conventional keyboards.

However, for aesthetic reasons, many Color Computer owners have opted to replace the simple looking keyboard with a more conventional style computer keyboard. Adapting other keyboards, such as from the Model I, is not especially difficult, but as it involves some soldering and trace cutting, is somewhat beyond this book. However, for the more adventurous, see the November 1981 issue of 80 Microcomputing Magazine (80 Pine St., Peterborough, N.H. 03458) for details on this modification.

One of the few complaints related to the stock Color Computer keyboard is that of sticking keys. Application of a fine graphite lubricant (used to free up locks) will eliminate this problem.

The PIAs strobe the keyboard (INKEY\$) and tell the computer which key has been struck. It does this with two ports -- one which reads the keyboard rows, the other which reads the keyboard columns. It has divided the keyboard into a matrix of eight rows by eight columns, and is thus able to determine which of 64 different keys has been struck.

The fire buttons of the joysticks are in parallel with two rows of the keyboard, which is why, in some Color Computers, garbage keystrokes show up on the screen when the joystick buttons are pressed (this has been rectified in more recent computers -- see chapter on ROMs).

## JOYSTICKS

The joystick ports can be used to input various kinds of data, as directed by the PIA.

The joysticks themselves are composed of two potentiometers, one for vertical movement of the stick, the other for horizontal movement. Should either of these pots fail, replacement pots are available from Radio Shack, and are easy to install. In this manner joysticks can be rejuvenated at much less than replacement cost.

The Color Computer measures both the horizontal and the vertical voltage for both the left and right joysticks. These voltages are then compared by a digital-to-analog converter, which then does a series of rapid calculations to determine the exact co-ordinates of either joystick at any given point in time. As the D/A is only a six bit converter, the Color Computer can accept only a maximum 64 x 64 matrix (ie. 0-63 on the X-axis and 0-63 on the Y-axis).

As they measure voltage, the joystick ports are not limited to being used with joysticks alone but can be used with a myriad of other devices designed to operate on comparative voltages such as light pens, thermocouples, anemometers, etc.

For further information see the January through April 1982 issues of BYTE Magazine (70 Main Street, Peterborough, N.H. 03458).

## CASSETTE

The cassette port can be used for both input (CLOAD) or output (CSAVE) as determined by the PIA.

Data is stored on cassette in a format known as Frequency Shift Keying or FSK. FSK employs two different frequencies to record

the data in binary form - a high frequency signal (2400 Hertz in the case of the Color Computer) to record the "1"s and a lower frequency signal (1200 Hertz) for the "0"s.

These two waves are generated as sine waves, and are interpreted by the computer with a digital-to-analog converter.

The format of each tape is as follows:

1. A 128-byte leader.
2. This is followed by a file name block. Each file name block consists of an 8-byte name, and then 1 byte for file type (00=BASIC, 01=Data, 02=Machine Language), 1 byte for the ASCII flag (00=Binary, FF=ASCII), 1 byte defining the gaps (01=Continuous, FF=Gaps), 2 bytes for the start address of a machine language program and 2 bytes for the load address of a machine language program.
3. Approximately 1/2 of a second of blank tape follows (this is to allow the BASIC compiler time to evaluate the file name).
4. A second 128-byte leader.
5. The data blocks. Each data block consists of a leader byte, a sync. byte, type of block byte (File name=00, Data=01, End of File=00H), data (0 to 255 bytes), checksum byte (the sum of all blocks written for the data block), and one trailer block.
6. End of file block.

As you can see the format is relatively simple and quite fast -- at either 1200 or 2400 baud.

Errors in anyone of the input bytes can cause that dreaded IO ERROR message to appear. However, the culprit is nearly always the checksum byte (step 5). After each data block, the computer compares the number of bytes of information it received with the number of bytes the checksum byte told it it should have received. If there is a discrepancy... it's IO ERROR time!

#### MERGING BASIC PROGRAMS

---

When the Color Computer CLOADs a program, it sets a number of file pointers on receipt of the End-of-File block. This is to prevent a second program from being loaded over top the old one. Thus, when it receives a new File Name leader, it



clears out its memory to make place for the new program.

This is usually very convenient (for those of us who forget to type in the NEW command) most of the time, except when we would really rather merge two programs.

If you have a really good ear, and very fast fingers, the solution is relatively simple:

Switch off the cassette just before it reaches the End-of-File block (if you listen to tapes via the cassette speaker or with the AUDIO ON command, this block is very distinctive). Cue up the second program you wish merged with the first, omitting the blocks numbered 1 through 4 above and starting with the first data block.

Pretty easy, No? Well for those of us less not endowed with nimble fingers there is fortunately an easier and more practical way.

1. CLOAD the first program. Make sure it has no lines in conflict with the program you plan to merge it with (RENUM if necessary) -- and watch out for CLEAR, DIM, DATA and RESTORE statements which can really confuse the issue if you're not careful.

2. Check to see where the beginning and end pointers of the first program are:

B1 = PEEK (25)  
E1 = PEEK (26)

3. Determine the beginning and end points to be used by the 2nd. program you will be loading:

Beginning (B2) = PEEK (31)  
Ending (E2) = PEEK (32)-2

4. Change the program pointers after you have the values for beginning (B2) and ending (E2), as follows:

POKE 25, B2 (where B2=beginning value from above)  
POKE 26, E2 (where E2=ending value from above)

5. CLOAD your second program.

6. Restore the pointers to the values you determined in step 2 above.

POKE 25,B1 (where B1=the beginning value obtained in step 2)

POKE 26,E1 (where E1=the ending value obtained in step 2)

7. Now you are ready to RUN, LIST, CSAVE, etc., the merged program.

That's a little bit more complex, but the results are somewhat more repeatable.

## RS232 INTERFACE

---

The RS232C Interface used on the Color Computer is comprised of only four pins, as compared to most other computers which use a 25-pin RS232 connector.

In the Color Computer these are as follows:

1. CD - the status input line.
2. RS232 IN - the serial data input line.
3. GROUND - the zero voltage reference line.
4. RS232 OUT - the serial data output line.

As with the cassette port, the RS232 port can be either an input port (e.g. for a modem -- in which case it uses lines 1, 2 and 3) or as an output port (e.g. for a printer -- in which case it uses lines 1, 3 and 4). The input or output format is determined by programming the appropriate PIA.

It is relatively easy to adapt the four pins to a 25 pin system (only three of the 25 pins are actually necessary for the conveyance of data). The next chapter describes the modifications necessary for a serial printer -- the principles are the same for a modem or any other serial device.

## 8 - DEALING WITH PRINTERS

The Color Computer can accommodate a wide range of printers through its built-in RS-232 (labelled SERIAL I/O on the rear panel of the computer) interface. However, those who have tried to connect parallel type printers (Epson, Centronics, Micro Line, Okidata, etc.) or non-Radio Shack serial printers have likely experienced some difficulties.

Currently, there are only two printers which are off-the-shelf compatible with the Color Computer, and its 4-pin serial RS-232 port -- the Radio Shack Line Printer VII and Line Printer VIII. That's not by any means to say that other printers are not adaptable, only that some modifications will be required.

In order to function, parallel printers will require a serial-to-parallel interface. This device, which may be installed either inside the printer as an option or added externally (ie. the Micro Works' excellent PIBOC interface), fools the Color Computer into thinking that it is communicating with a serial printer. For printers using a built-in serial interface, a Radio Shack cable will have to be adapted to allow the 4-pin output of the Color Computer to connect to the 25 pin input on the printer.

Basically, only three of these 25 pins are required for most printing purposes. The Color Computer RS-232 port is set up as follows for use with a printer (pin numbers are marked on the male connector plug):

Pin 1 - Not used with printer

Pin 2 - Connected to the status or busy output line of the printer (tells the computer whether or not the printer is ready to accept data). If your printer does not have a status line, then this pin must be connected to a source of positive voltage between +3 and +12 volts (this will tell the computer that the printer is ready at all times).

Pin 3 - The signal ground.

Pin 4 - Serial data input line to the printer (computer data output line).

It is usually a pretty simple matter to purchase a Color Computer printer cable, cut off one connector and hook up the appropriate three wires to the printer. Once this is accomplished, then you must either flick the appropriate switches in the interface to meet the computer's default printer assumptions or POKE in the appropriate values on power-up.

When the Color Computer is turned on, unless told otherwise, it will expect a printer which:

- 1 - Operates at 600 Baud (ie. accepts input at 600 bits of data per second).
- 2 - Has a width of 132 characters (or columns).
- 3 - Generates a busy output when ready (see information under Pin 2 - above).
- 4 - Executes a carriage return at the end of each line.
- 5 - Accepts data as per the following format: One start bit (logical zero), 7 or 8 data bits (depending on whether you have version 1.0 or 1.1 of Color BASIC -- see explanation later in text) with the Least Significant Bit first, two stop bits (logical one) and no parity.

If your printer meets these default conditions or can have switches or jumpers set to meet these conditions, then you're off to the races. Otherwise, you will have to resort to POKEing in new values each time you turn your computer on. It is decimal addresses 149 to 155 which set the printer conditions.

If you check after turning the computer on, you will see that:

PEEK (149) returns a 0 (this is the Most Significant Bit or MSB establishing the Baud rate).

PEEK (150) returns an 87 (Baud rate Least Significant Bit or LSB).

PEEK (151) returns a 0 (Line delay MSB).

PEEK (152) returns a 1 (Line delay LSB).

PEEK (153) returns a 16 (Comma width field -- this is the number of spaces allowed to print a variable value).

PEEK (154) returns a 112 (Last comma field).

PEEK (155) returns a 132 (Line printer width).

These values may be changed as follows:

#### CHANGING THE BAUD RATE

If your printer only accepts data at a rate other than 600 Baud, you must change the values at both locations 149 and 150. To change the Color Computer's output to:

120 Baud - type POKE 149,1;POKE 150,202

300 Baud - type POKE 149,0;POKE 150,180

600 Baud - type POKE 149,0;POKE 150,87 (this is the default setting of the computer).

1200 Baud - type POKE 149,0;POKE 150,41

2400 Baud - type POKE 149,0;POKE 150,18

#### CHANGING THE LINE DELAY

To set the line delay to other than the default value two POKES must be entered. For delays of:

0.288 seconds - type POKE 151,64;POKE 152,0

0.576 seconds - type POKE 151,128;POKE 152,0

1.15 seconds - type POKE 151,255;POKE 152,255

#### CHANGING THE PRINTER WIDTH

If your printer accepts other than 132 characters per line, POKE the appropriate value into location 155. In other words, for:

16 characters/line - type POKE 155,16

32 characters/line - type POKE 155,32

64 characters/line - type POKE 155,64

255 characters/line - type POKE 155,255

NOTE -- These POKES have to be entered each time the computer is turned on, as on power-up it will return to the original default values (1 to 5 above) as dictated by the Color BASIC ROM.

#### SEVEN OR EIGHT BITS -----

This brings up the question raised earlier -- is it seven bits or eight and who really cares...?

If, when you turn it on, your computer displays the message:

COLOR BASIC 1.0  
(C) 1980 TANDY

then you have version 1.0 of BASIC and your computer sends only seven bits of data to the printer.

If, on the other hand it displays:

COLOR BASIC 1.1  
(C) 1981 TANDY

then you have version 1.1 of BASIC and your computer sends eight bits of data to the printer.

NOTE -- If you have Extended Color BASIC installed PEEKing location 41301 will determine which version of Color BASIC you have. If PEEK (41301) returns a 49 you have version 1.1; if it returns a 48 you have version 1.0. You can also tell the computer to EXEC 41175, in which case it will display the Color BASIC message rather than the Extended BASIC message.

What's the difference anyway, you ask?

As you know, all computer transactions are binary (ie. a series of "1"s and "0"s). This is true both within the computer and with the information it transmits to the printer. In other words, the number 0 in binary is 0000, the number 1 is 0001, the number 2 is 0010, the number 3 is 00011, etc.

With a seven bit system, you can send codes to the printer from binary 0000000 to 1111111 or decimal numbers from 0 to 127. That's usually fine for most printing requirements as nearly all characters lie in that range -- CHR\$(0) to CHR\$(127). However, what if you want to print a more exotic character such as the British symbol for pounds - CHR\$(193) - or graphics characters? Then you need the capability to transmit the full eight bits of data from binary 00000000 to 11111111 or decimal 0 to 255.

If you have version 1.1 of Color BASIC, then that's no problem. However, if you have version 1.0 then you will need to supply the eighth bit via a software routine known as an Eight Bit Driver. Such a driver program is available free of charge from Radio Shack Computer Centres. Just ask for the PTFX Program (R.S. Part No. 700-2013).

Now, if you wondered why you weren't able to access the dot-addressable graphics capability of the Line Printer VII, you'll know why. Incidentally, the Radio Shack Screen Print Program has its own built-in driver, and does not need the PTFX Program to operate.

Finally, while on the subject of printers, here is another PEEK you might find of interest:

You can test for the status of your line printer by PEEKing into the Peripheral Interface Adapter at location 65314.

If PEEK (65314) returns a 4 or a 6, then the printer is on line.

If it returns a 5 or a 7 then it is off line. Routing information to the printer via a PRINT #-2 statement while the printer is off line (or disconnected or turned off) will cause the computer to hang up (will not execute the next line of a program or accept input from the keyboard). The only remedy to this situation is to hook up and/or turn on the printer (it may lose a few bits of printer data in the process) or press the <BREAK> or <RESET> keys.

See the chapter on UTILITY PROGRAMS for two printer utilities -- setting the printer line width and executing an automatic line feed after each carriage return.

## 9 - READ ONLY MEMORY

As we mentioned earlier, the Color Computer is a Read Only Memory or ROM-based 6809 system. In other words, the Color Computer has its operating system and language permanently burned into ROMs rather than having to load an operating system program each time the computer is powered up.

These ROMs consist of one or more 8K 68A364 chips which have the operating system and compiler preprogrammed in their 8,192 memory locations.

There are three operating systems available for the Color Computer: Color BASIC, Extended BASIC and Disk BASIC. Each uses the commands of its predecessor as subsets. Therefore you cannot have Extended BASIC without Color BASIC or Disk BASIC without Extended BASIC and Color BASIC.

Two of the three systems (Color and Extended BASIC) are located inside the computer. The other (Disk BASIC) is in a plug-in module inserted in the ROM expansion port.

Color BASIC (the ROM chip located in position U3 of the printed circuit board -- see next chapter for details) occupies addresses decimal 40960 to 49151.

Extended BASIC (position U28 on the printed circuit board) occupies addresses decimal 32768 to 40959.

Disk BASIC occupies the same areas as other ROM cartridge programs -- addresses decimal 49157 to 65279.

### COLOR BASIC 1.0 AND 1.1

As we mentioned in the last chapter, there are two versions of Color BASIC now available for the Color Computer.

If, when you turn it on, your computer displays the message:

```
COLOR BASIC 1.0  
(C) 1980 TANDY
```

then you have version 1.0 of BASIC.



If, on the other hand it displays:

COLOR BASIC 1.1  
(C) 1981 TANDY

then you have version 1.1 of BASIC.

However, if you have Extended Color BASIC installed, you will be unable to see at a cursory glance which version is installed. Plug in the joysticks, and press one of the fire buttons. If you get a jumble of characters displayed on the screen, then you have version 1.0.

Another way to tell which version of Color BASIC you have, on a machine equipped with Extended Color BASIC, is to PEEK at location 41301. If PEEK (41301) returns a 49 you have version 1.1; if it returns a 48 you have version 1.0. You can also, by instructing the computer to EXEC 41175, get it to display the Color BASIC message rather than the usual Extended BASIC message.

What's the difference anyway, you ask?

Radio Shack has made certain enhancements with version 1.1. For example, this new version (which first reached the market in late 1981), will:

1. Operate with either 4K, 16K or 64K dynamic RAM chips (version 1.0 accepts only 4K or 16K chips).
2. Eliminate the garbage characters generated on the screen when the joystick fire button is pressed.
3. Change the RS232 output from seven bits to eight bits (see chapter on Printers for details).
4. When searching for a file name during a CLOAD the upper left hand corner flashes when skipping over invalid files.
5. The CLOSE routine was changed to automatically write an End-of-File block when the character buffer is empty.

Adding to or replacing these ROMs is described in detail in the succeeding chapters. ROMs are available from most Radio Shack Computer Repair Centres or from Radio Shack National Parts in Fort Worth, Texas.

## 10 - TAKING A LOOK INSIDE

The only way to get a really good understanding of how your Color Computer works is to take off the cover and have a look inside. This will not only give you a better idea of where all the parts are, what they look like and how they interrelate, but will give you an understanding of the expansion capabilities of your particular machine.

This chapter is written as a preamble to the following three chapters on upgrading the computer to 16K, 32K and 64K of RAM. Please read this chapter first, carefully, before proceeding to the upgrade chapters.

Despite what you may have heard or read, going inside your Color Computer, whether it's just to have a look around or to add Extended BASIC, more memory or one of the myriad of add-on kits now appearing on the market (such as lower case letter mods., monitor ROMs, etc.) is neither very difficult nor dangerous.

Modern microprocessors are much more sturdily built than their predecessors, and you really have to try pretty hard to do anything to damage them.

So, if you're curious about what makes the gray box tick then read on. It's really very simple--just follow the instructions and you can't go wrong.

First a word of CAUTION! Opening the case of your Color Computer will void the Radio Shack warranty. If your computer is still covered under the 90 day warranty period, you might first want to check that all systems are functioning properly by using the Radio Shack's diagnostic ROMPAK. Our experience has shown Color Computers to be highly reliable in operation, and to require little in the way of servicing.

Okay, enough of that--on to the good stuff. In order to take a peek inside, you will need the following two tools: a Phillips screwdriver and a small sharp knife or razor blade.

Proceed as follows:

1. Remove any interface cables (cassette, joystick, video output, etc.) from the rear of your computer, and UNPLUG the computer. Make sure you actually unplug the computer, and don't

merely turn off the power. This is because the transformer of the Color Computer continues to suck power whether it is turned on or not. Try this sometime: When the computer is turned off put your ear to the vent holes on the top left hand side of the computer and listen to that transformer hum. The transformer is usually one of the first things to fail in the computer, which is why, if the machine is not going to be in use for awhile, it is a good idea to unplug it.

2. Flip the computer over, and you will see nine visible screw holes on the bottom. Only six of these are actually used (see illustration) -- the two at the very back, the two immediately below those, and the two at the very front. Remove the screws from these with your Phillips screwdriver. The seventh and final screw is located under that small black warning label located in the centre of the computer. You may be able to carefully remove this label using a razor blade and a lot of patience. Otherwise just punch a hole in the centre of the label and remove the screw that it hides.

3. Carefully flip your computer back rightside up, being careful not to lose any of the seven screws. Lift up the top of the gray cover (it snaps together, and you may have to gently separate the two halves by inserting a couple of fingers carefully into the ROMPAK port and gently pulling the two halves apart).

You're inside, at last!

4. With the cover off, you will see a large metal shield covering the top right hand corner of the printed circuit board (to the right, just above the keyboard). This cover is an R.F. (Radio Frequency) Shield (prevents the computer from causing interference on nearby television sets) and it hides the main computer components.

The shield may be held in place by a couple of white or clear plastic shipping straps (usually one at the front -keyboard- edge and one at the right -ROMPAK- edge. If this is the case, merely cut through these straps with your knife or razor blade (they serve no useful purpose after shipping) and remove them.

Now, carefully pry off the metal cover (sometimes this requires a little force as it fits together pretty tightly), examining how it fits together so you can later replace it.

Whew! That wasn't so bad, was it?

Can you believe that there's actually so little to this incredible machine? Those eight small chips immediately above the keyboard, to the right, labelled from right to left U21 through U27 are your read/write memory or RAM (note - the ninth chip in that row, labelled U11, is not a memory chip).

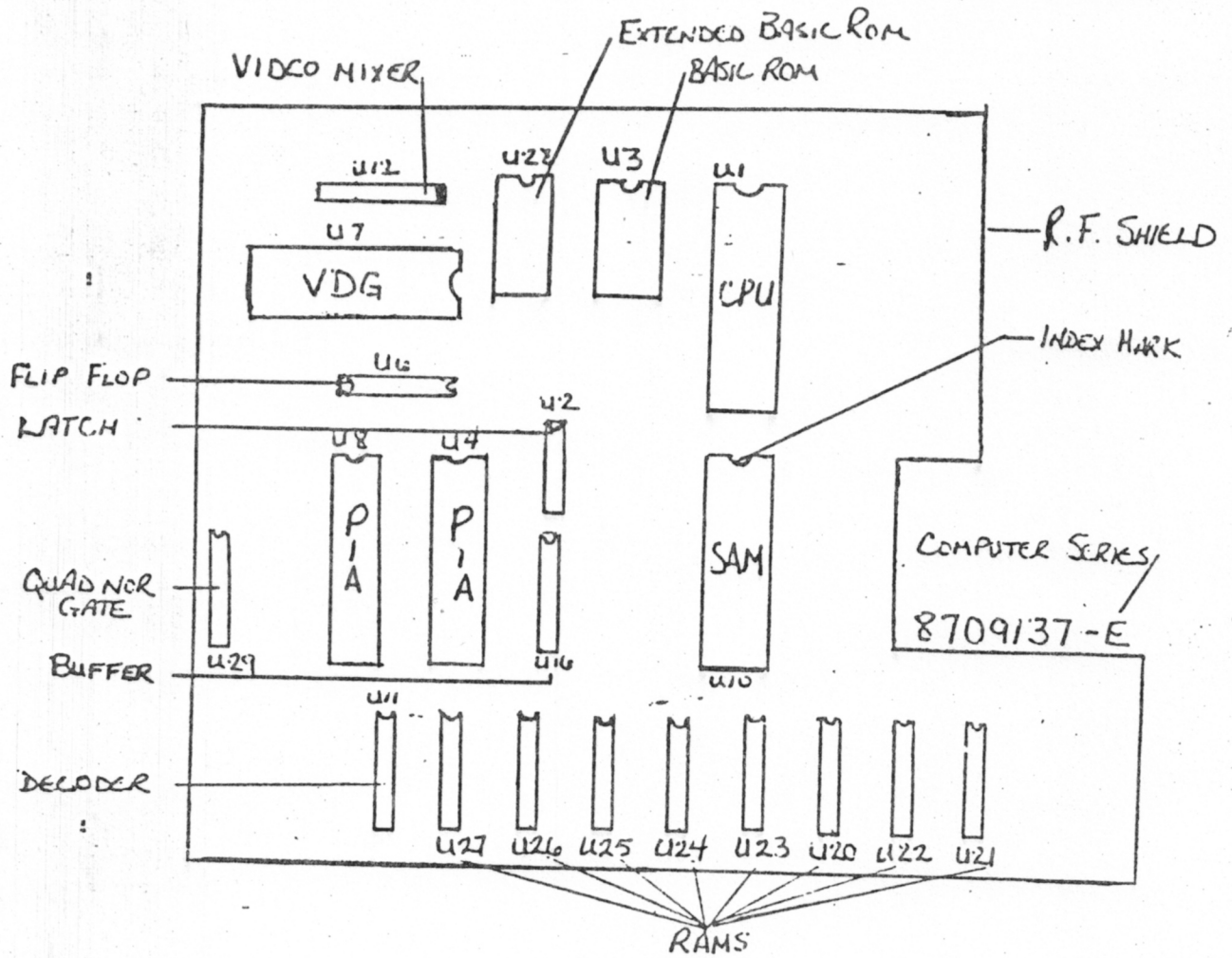

CHIPS INSIDE THE COLOR COMPUTER'S R.F. SHIELD (above).

INDEX NOTCH AND CHIP PIN NUMBERING SEQUENCE (below).

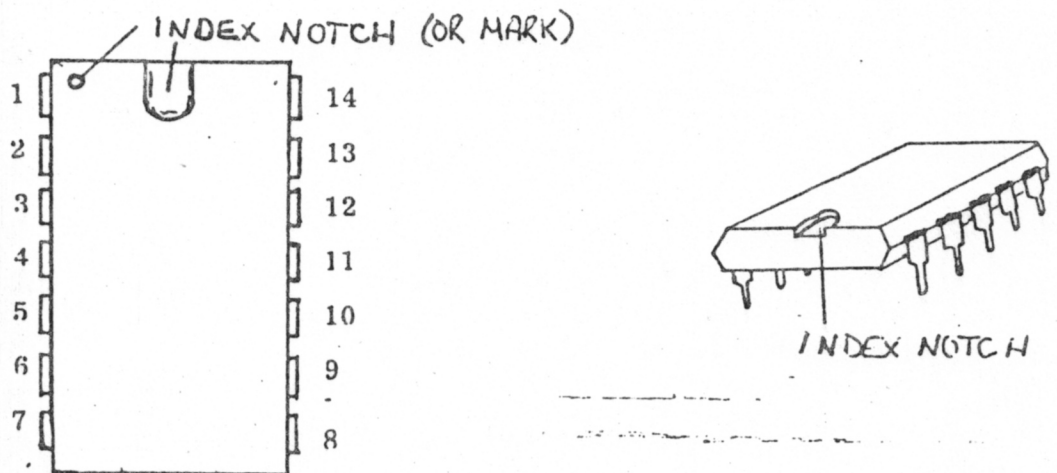

Note the little notch markers and/or small white dots on the top of each chip (see illustration). These index marks are important to remember if you plan on removing any chips (for a memory upgrade, for example) as they indicate the polarity of the pins, and any new chips must be inserted with the notch in the same position.

While on the subject of chips, you might, in some magazine article or other, have seen references to pin numbers. The little feet (or pins) of all chips are numbered from one up starting at the top left hand corner (the top edge has the marker notch or dot) and proceeding counter-clockwise down the left hand side of the chip and back up the right side to the top right hand corner (see illustration).

### DETERMINING THE COMPUTER SERIES

-----

Let's determine which series of Color Computer you have.

Look for the number just outside the area that was covered by the R.F. shield. It's on the right hand side between the shield and where the ROMPAKS plug in (see illustration).

The number may be something like:

8709137-E

It is the letter suffix which indicates which series Color Computer you have (as of this writing series "A" through "E"). This letter indicates the type of printed circuit board used in your model.

Chances are that you have a "D" or an "E" series computer. The "D" series were predominantly sold during 1981 with the "E" being introduced in late November of 1981. No external differences in these machines are readily apparent. Color Computer series A through D used version 1.0 of Color BASIC (if you do not have Extended BASIC see the sign on when you first power up your computer to determine whether you have version 1.0 or 1.1. If you have Extended BASIC - ask the computer to PRINT PEEK (41301). If it returns a 49 you have version 1.1). The last of the D series and all of the E series computers have version 1.1 of Color BASIC.

If you have a D series computer, look for a couple of jumpers marked 4K-16K. They're located between chips U8 and U4 (the numbers are marked in green right on the printed circuit board), and immediately to the right of chip U10 (see illustration). There are 3 pins associated with each jumper (a black plug-in connector which joins together two of the three pins). These jumpers tell the SAM chip (chip U10) which type of RAM chips you have installed (4K or 16K).

If you have a set of five pins labelled 16K - 32K - 4K between chips U8 and U4 then you've got one of the new E-type printed circuit boards.

With the A through D series Color Computer you must first upgrade to 16K chips before you can upgrade your computer to 32K. With the E series Color Computer you can upgrade your computer directly from 4K to 32K or 64K using the new 64K RAM chips.

The A through D series upgrade to 32K is accomplished by installing a RAMCHARGER Board (Spectral Associates plug-in printed circuit board which contains an additional 16K of memory) to augment the 16K chips or by piggybacking a second set of 16K chips on the first.

The E series upgrade to 32/64K is achieved by replacing the existing RAM chips with new 64K ones. Therefore, if you have an E series computer, your best bet is to upgrade directly from 4K to 64K, thereby saving yourself the cost of intermediate 16K chips, which will just be thrown out when you replace them with the 64K chips.

The A through D series Color Computer will not accept 64K RAM chips as they lack the necessary jumpers to program the SAM chip (in actual fact this can be done - but it involves cutting traces on the P.C. board and some in-depth knowledge of electronics and is outside the scope of this book). These computers use the 16K chips as the basis for other upgrades.

#### TAKING A LOOK AROUND

Enough on memory upgrades for the time being (see the following chapters for details on how upgrades are accomplished). Let's take a look around inside.

At the top (near the back of the computer) you will see a chip marked U3 (see illustration). This is your Color BASIC ROM. If you do not have Extended Color BASIC installed, you will see an empty socket (U28) immediately beside it. That's where the Extended BASIC ROM chip goes.

You can purchase an Extended BASIC kit from Radio Shack (it contains the chip and a manual) and install it yourself if you like, saving yourself the \$20-25 installation fee. All you do is plug the chip in the socket, and you're done!

Some of the other chips (see illustration) you see inside are the microprocessor chip (U1); the video display generator (U7); the SAM chip (U10); and the video mixer (U12).

Outside of the area covered by the R.F. shield, to the left, are the transformer and voltage regulator sections of the Color Computer. Those funny looking black pieces of metal pointing up in wierd directions on the left are heat sink fins, which aid in keeping various internal components cool.

That little silver box between the top of the R.F. shield and the back of the computer is the R.F. converter which allows your Color Computer's signal to be viewed on a regular television set rather than necessitating a more expensive computer monitor.

If you have problems with your computer crashing every once in awhile for no known reason, perhaps you have a cooling problem. Try touching the SAM chip (U10) sometime after running your computer for awhile. If it's particularly warm, buy a couple of small heat sinks (get the black, finned variety, type TO-220 or equivalent) to help in keeping it cool. These are attached by using a small amount of special silicone heat sink grease. Bend up the fins of the heat sink so that when they are put in place they just touch the underside of the R.F. shield when it is put back in place. This will hold them down (and assist with the cooling). You might also want to add a heat sink or two to the 6809 microprocessor chip (U1) as well.

#### REPLACING THE COVER

Well that's about all there is to it. Once you are finished looking around, proceed as follows:

1. Check to make sure you've removed all your tools from inside the computer.
2. Replace the metal R.F. shield cover and press it firmly in place.
3. Ensure that the keyboard is resting squarely on its pegs, and replace the gray plastic top of the computer.
4. Turn the computer over, upside down, and replace the seven screws (the two short ones go at the front edge under the keyboard).

That's it! Didn't know you had it in you, did you?

## 11 - CLEARING MORE MEMORY

If you've upgraded your computer from Color BASIC to Extended Color BASIC you've probably discovered, much to your horror, that you've been robbed of some memory -- and quite a bit of memory at that.

A regular non-Extended Color Computer, with 16K of RAM installed, will, if you instruct it to PRINT MEMEORY give you a reading of around 15,000 bytes. Take that same computer, however, and plug in the Extended BASIC ROM, and to the same statement it will report only 8,487 bytes.

Where has the extra 8K gone and why?

Well there's a fast and simple way of recovering most of that lost memory -- through software -- and best of all it's absolutely free.

First, however, a word or two is in order about where all that memory went.

On turning on your Color Computer, the two BASIC ROMs (Color BASIC and Extended Color BASIC) go into almost instant action, checking internal components, initializing variables, protecting memory, etc.

This initialization process ensures that all numeric variables are set for 0 and all string variables are set for " ". It also sets aside a protected area of memory for the computer to keep track of where it is in the execution of a program, the current value of all variables, a "scratch pad" area for calculations and for other miscellaneous overhead.

As part of this process, the Color Computer establishes numerous default values for such things as printers, keyboard input, etc., etc. One of these defaults is CLEARing a fixed amount of space for variable storage - so that for a small program the programmer can forget about putting in a CLEAR statement and still have everything run okay.

These default values can be altered by instructing the microprocessor to change them to something else. For example, printer defaults can be changed by POKEing certain values into



locations 149 through 155 (see the chapter "Dealing With Printers" for details). This must be done each time the computer is turned on -- otherwise it reverts to default values as instructed by the BASIC ROMs.

The CLEAR default, for example, sets aside 200 bytes of RAM for variables -- the equivalent of a CLEAR 200 statement. Two hundred bytes is a lot of space, probably more than the average program ever uses. CLEAR less space, and you'll have more memory available for other uses.

Try the statement CLEAR 0, followed by PRINT MEM and see how you free up additional memory.

Similarly, Extended BASIC protects four pages of memory for graphics use. That four pages of graphics uses up an extremely large area of RAM -- the equivalent of a PCLEAR 4 (PCLEAR = Page CLEAR) -- or about 6K. Now if you don't need all that graphics area and want to do some serious "number crunching" instead, try a PCLEAR 1, followed by a PRINT MEM, and you've got yourself a total of 13,095 bytes for your programming! Not bad.

Well, can't I use a PCLEAR 0 and get rid of all the reserved graphics area? Nice try, but sorry -- no. Microsoft didn't include PCLEAR 0 in the Color Computer's memory. But that doesn't mean to say it can't be done.

Address decimal 25 in the Color Computer stores the beginning of the BASIC program. By POKEing a 6 in that location you will cause BASIC to be loaded at HEX location &H0601 -- giving you an additional 1.5K of memory.

Try typing in the following:

```
POKE 25,6:NEW
```

Type in PRINT MEM and you should get 14,631 bytes of RAM -- not bad for a computer that just a few minutes ago gave you little more than 8K! (Note -- if you are using DISK BASIC, this POKE will not work -- see the end of this chapter for details).

Still not satisfied?

Well, as we said, at power-up, the computer grabs a little memory for itself -- and that is the missing 1,536 bytes. This protected area is located between address 0 and 1,535.

The Color Computer uses addresses 1024 to 1535 to store and display the low-resolution or text screen information (see the chapter on Memory Mapping which explains how this area works) -- which is absolutely essential unless your program uses only the high-res graphics pages.

Similarly, it sets aside the bottom 429 bytes -- from addresses 0 to 428 for pointers, buffers, interrupt vectors, etc. and all

the other goodies necessary for the proper execution of your programs.

However, we have found that the addresses 429 to 1023 are seldom used (except for locations 729 to 753 and 981 to 996 -- which are used for some of the editing and CLOAD/CSAVE functions) and can usually be stolen without the computer being any the wiser.

That's an additional nearly 600 bytes -- and that can sometimes mean the difference between life and death for an almost 16K program! However, this area cannot be used for BASIC program storage, but it can be used for POKEing in and later retrieving values (such as the utility driver programs listed in Appendix 1).

If you're using a disk drive, the 25,6 POKE will not work. That's because the Disk Operating System uses RAM addresses Hex &H0600 to &H0988. To free up the additional RAM when using the disk system type:

```
POKE 25,&H0E:POKE 26,&H1:POKE &H0E00,0
```

Now how's that for memory expansion for free?

## 12 - UPGRADING TO 16K RAM

If you've been frustrated by your inability to run larger programs or are looking forward to using some of the commercially available software which says they "require a minimum of 16K RAM", then perhaps you should consider upgrading your 4K machine to 16K.

If you're lucky enough to have an E series Color Computer (see previous chapter to determine which series computer you have) and you can afford it, you should go right to a 32K or 64K upgrade (see chapter on upgrading the E series) and save yourself the bother and cost of installing 16K chips.

A through D series Color Computer owners will have to complete this 16K upgrade before adding more memory (say to 32K) or installing the Extended BASIC ROM.

Here's how it's done:

Purchase eight 16K x 1 bit dynamic RAM chips (these are known variously as 4116, 416, MM5290N or UPD416 dynamic RAM chips, depending on the manufacturer). You should buy the 200 nanosecond (slightly more expensive) variety if you wish to use the speed-up POKE (see chapter on The Myth of the Speed-Up POKE), although 250 n.s. chips will probably also work okay if nothing else is available (note -- premium quality 200 n.s. chips along with complete installation instructions are available in kit form from Disk 'n Data).

You will need the following tools for this upgrade: Phillips screwdriver, sharp knife or razor blade, chip extractor or nailfile or small jeweller's screwdriver.

Make sure the power is turned off and the power cord is unplugged. Open up your Color Computer as described in steps 1 - 4 of the previous chapter (Taking a Look Inside).

Remove the R.F. shield as described in step 4 (using the knife or razor blade to cut the shipping straps if you haven't done this before).

Under the R.F. shield locate eight small chips located immediately above the keyboard, to the right. They are labelled from right to left U21 through U27 (these numbers are etched in

green right in the printed circuit board). These are your 4K read/write memory or RAM chips (note - the ninth chip in that row, labelled U11, is not a memory chip).

Chips U21 through U27 must be removed, one at a time, and the eight 16K chips substituted for them.

Notice the little notch (or the white dot) cut into the top of each chip? These are the index marks and indicate the polarity of the pins. The new chips must be inserted with the notch in the same position as the old chips (the notch should be towards the back of the computer).

In order to extract the old chips, use your chip extractor to securely grasp and pull out each chip. If you do not have an extractor tool then use a small nailfile or jeweller's screw driver and insert it under each 4K RAM chip in turn, pry it up slightly, rock it slowly from end to end, and lift it out of the socket.

Carefully slide one of the new 16K chips out of one of the ends of the static resistant shipping tube. Place it in the socket, taking care that each of the 16 pins lines up with the corresponding holes in the socket, and that the notch is oriented in the proper direction (should be pointing towards the rear of the computer).

Be sure that no pin slips outside the socket, and that no pin is bent up under the chip. The chip fits tightly in place once it is fully inserted in its socket.

Do this for each of the other seven chips in turn.

Now, take a deep breath--you're nearly done!

There are two small black or blue jumpers which need to be moved in order to tell the computer that you've got 16K RAM chips in place. They're located between chips U8 and U4, and immediately to the right of chip U10 (see illustration on p. 35). Associated with each jumper are three pins marked 4K and 16K.

Lift off each jumper and move it so it connects the middle pin to the 16K pin leaving the 4K pin free.

If you have another set of pins labelled 32K then you've got one of the new E-type printed circuit boards (late 1981-on). In any case, place the two jumpers in the 16K position. You do not need to move any of the other jumpers on the E-board.

That's it! Double check your work ensuring that the two jumpers have been moved, and that all eight 16K chips have been installed and that all the pins are properly inserted in their sockets.

Make sure that all of your tools are out of the way. Plug in

the computer, and power up; you don't need to replace the cover for this test--but be sure to keep your hands out of the works!

The screen will clear, but the Color BASIC message will take a little longer than normal to appear. Type in PRINT MEM, and you should discover better than 14K of RAM available (or approximately 8K in an Extended BASIC machine -- see chapter on Clearing More Memory to discover how to recover this "lost" memory).

#### WHAT COULD GO WRONG

-----

Problems will show up as a "locked up" machine, only 4K of memory still reported after a PRINT MEM, or random crashing.

A "locked up" machine indicates RAM chips inserted backwards (notch on the wrong end), pins crushed underneath or outside the sockets, or (least likely) a bad memory chip. Recheck your work.

If only 4K of memory is reported after PRINT MEM, make sure that the jumpers are properly placed in the 16K position. Too little memory might also point to a bad memory chip. Power up a few times and see if the PRINT MEM value changes each time. If that is the case it is possible that one chip is functioning too slowly and needs to be replaced.

Random crashing most likely indicates one or several chips not fully inserted in their sockets.

#### COMPLETING THE JOB

-----

If all is well, remove the line cord. Remember, because the computer's power supply is inside the case, it's always "live" when the power cord is still plugged in!

Before you reassemble everything, you might want to take this opportunity to install the Extended BASIC ROM chip. It goes in the empty socket (U28), near the rear panel of the computer. You can purchase the Extended BASIC ROM upgrade kit from a Radio Shack Computer Repair Centre (the kit contains the chip and a manual) and install it yourself (you may have to fill out a waiver of warranty to obtain the kit) saving yourself the \$20-25 installation fee. All you do is plug the chip in the socket, and you're done!

Now replace the metal R.F. shield and follow the instructions for replacing the cover outlined in the previous chapter.

## 13 - UPWARD FROM 16K TO 32K RAM

So you've discovered 16K of memory still isn't enough? Well how about 32K then? It isn't all that much more expensive or difficult to install.

There are several ways of accomplishing the 16K to 32K upgrade. If you have an E series Color Computer you may wish to remove the 16K chips and proceed with the 32K-64K upgrade outlined in the next chapter. However, an E series Color Computer can also be upgraded in piggyback fashion, the same as an A through D series.

Here's how the A through D series (and E series piggyback) 16K to 32K upgrade is accomplished:

Of the numerous methods of upgrading the 16K computer to 32K the easiest is the installation of a RAMCHARGER board from Spectral Associates (also carried by Disk 'n Data). This is a printed circuit board which contains an additional 16K of RAM already installed.

The RAMCHARGER board is plugged right in to your existing Color Computer (complete instructions are included with the RAMCHARGER kit so we won't go into them here) without modification. The advantages here are that installation is simple -- no soldering is required, and if any servicing is necessary in the future the board can be pulled out and no one will be any the wiser.

The second method is piggybacking two 16K RAM chips and soldering them together to obtain 32K. This method, while slightly less expensive than the RAMCHARGER, requires some soldering experience. It will also probably mean that you'll have to be prepared to do your own maintenance and servicing, as Radio Shack is unlikely to work on a Color Computer with foreign components soldered in place.

### THE PIGGYBACK UPGRADE

---

However, for those of you who are willing to give it a shot, and have some soldering experience, here's how you proceed with the 32K piggyback upgrade:

Purchase a second set (by that I mean one set in addition to the first set already in your computer) of eight 16K x 1 bit dynamic RAM chips (these are known variously as 4116, 416, MM5290N or UPD416 RAM chips depending on the manufacturer). You should buy the 200 nanosecond (slightly more expensive) variety for piggybacking.

You will need the following tools for this upgrade: a Phillips screwdriver, sharp knife or razor blade, chip extractor or nailfile or small jeweller's screwdriver, small soldering iron (25 watts or less), pair of pliers or tweezers, some light gauge insulated copper wire, aluminum foil and a small ferite bead or 33 ohm resistor (optional).

Place a sheet of aluminum foil on the surface of your work area. This will give you somewhere to rest the chips when soldering them, and will not allow them to accumulate a build-up of static electricity, which could prove harmful.

Make sure the power is turned off and the power cord is unplugged. Open up your Color Computer as described in steps 1 - 4 of Chapter 11 (Taking a Look Inside).

Remove the R.F. shield as described in step 4 (using the knife or razor blade to cut the shipping straps if you haven't done this before).

Under the R.F. shield locate the eight small chips located immediately above the keyboard, to the right. They are labelled from right to left U21 through U27 (these numbers are etched in green right in the printed circuit board). These are your 16K RAM chips (the ninth chip in that row, labelled U11, is not a memory chip).

Notes: This piggyback upgrade must be accomplished with pairs of 16K chips (different manufacturer's chips can be mixed). It will not work with 4K chip piggybacked with 16K chips or vice-versa.

Chips U21 through U27 must be carefully removed, one at a time, for the piggyback operation. Notice the little notch (or the white dot) cut into the top of each chip? These are the index marks and indicate the polarity of the pins. Take note of which way the old chips are oriented as the piggybacked chips must be inserted with the notch pointing in the same direction (the notch should be towards the back of the computer).

In order to extract the old chips, use your chip extractor to securely grasp and pull out each chip. If you do not have an extractor tool then use a small nail file or jeweller's screw driver and insert it under each 16K RAM chip in turn, pry it up slightly, rock it slowly from end to end, and lift it out of the socket.

Place the chips you have removed on the sheet of aluminum foil you have placed on the surface of your work table. Carefully slide one of the new set of 16K chips from either end of the static resistant shipping tube. Place it carefully over top an old chip and check to see that the pins from the new chip tightly hug the pins of the old chip. Bend the pins of the new chip inward slightly until you get a good snug fit.

Bend up pin 4 on the new chip (see earlier chapter "Having a Look Inside" to determine pin numbering sequence) -- pin 4 is the fourth one down from the top left hand side of the chip -- so it juts out at a 45-degree angle with respect to the other pins.

Carefully hold the two chips (old on the bottom, new on top) together with a pair of pliers or tweezers so that all the pins (except pin 4) touch each other and the index mark on both chips is oriented in the same direction. Solder together the two number 1 pins. Do the same for pins 2 and 3, and 5 through 16.

Make sure that you do not have any bridges or cold solder joints, or that any blobs of solder will prevent you from properly reinserting the bottom chip. Don't use too much heat in the soldering process, or you could fry the chip. If it gets too hot to hold then stop, and let things cool down.

Do this for each of the other chips until you have eight pairs of 16K chips soldered together.

Now join each of the top chips' pin 4s together with a short length of the insulated copper wire. Do this daisychain fashion, allowing enough wire so that all chips will fit in their respective sockets (see illustration). Leave about a 10 in. length of wire attached to pin 4 on the last chip (the one that will be inserted in socket U27).

Carefully remove the SAM chip (U10) -- it has the number 6883 right on the top of the chip. Slip the small ferite bead onto the 10-in. length of wire connected to pin 4 of the last RAM chip (this is optional -- to reduce interference. You can also use a 33 ohm resistor spliced into the 10 inch wire to accomplish the same thing. Not all computers will experience interference with the piggyback mod -- you might want to check before installing the bead or the resistor). Solder the other end of the 10-inch wire to pin 35 of the SAM chip.

Now, reinsert all the chips back into their respective sockets, taking care to ensure that each of the pins lines up with the corresponding holes in the socket, and that the index marks are oriented in the proper direction (should be pointing towards the rear of the computer).

Make certain that no pin slips outside the socket, or bends up underneath the chip.



That's it -- you're done!

(Note -- no jumpers need to be moved for the 16K piggyback upgrade. Jumpers should be left as they were in the 16K position.)

Make sure that all of your tools are out of the way. Plug in the computer, and power up; you don't need to replace the cover for this test--but be sure to keep your hands out of the works!

The screen will clear, but the Color BASIC message will take a little longer than normal to appear. Type in PRINT MEM, and you should have better than 31K bytes of RAM available (24,871 bytes in an Extended BASIC machine).

#### WHAT COULD GO WRONG

-----

Problems will show up as a "locked up" machine with no sign on message, no evidence of the additional 16K of memory, or random crashing.

A "locked up" machine indicates RAM chips inserted backwards (notch on the wrong end), pins crushed underneath or outside the sockets, shorts between pins, chips damaged by heat (unlikely but still possible) or (least likely) one or more bad memory chips. Recheck your work.

If the second 16K of memory is not reported in a PRINT MEM, then the wire between the last RAM chip and the SAM chip is probably not properly soldered together. Too little memory might also point to a bad memory chip. Power up a few times and see if the PRINT MEM value changes each time. If that is the case it is possible that one chip is functioning too slowly and needs to be replaced.

Random crashing most likely indicates one or several chips not fully inserted in their sockets -- possibly from blobs of solder on one or more pins. It could also result in faulty soldering between one of the upper and lower piggyback sets.

#### COMPLETING THE JOB

-----

If all is well, remove the line cord. Remember, because the computer's power supply is inside the case, it's always "live" when the power cord is still plugged in!

Before you reassemble everything, you might want to take this opportunity to install the Extended BASIC ROM chip. It goes in the empty socket (U28) at near the rear panel of the computer.

You can purchase the Extended BASIC ROM in kit form from a Radio Shack Computer Repair Centre (the kit contains the chip and a manual) and install it yourself (you may have to fill out a waiver of warranty to obtain the kit) saving yourself the \$20-25 installation fee. All you do is plug the chip in the socket, and you're done!

Now replace the metal R.F. shield and follow the instructions for replacing the cover outlined in the previous chapter.

#### THEORY OF THE PIGGYBACK UPGRADE

-----

Here's the theory of what you have just accomplished:

All but one of the memory lines -- for both 16K and 32K -- are identical (addressing, data input/output, refresh and power). The only exception is the memory address (the lower 16K is located from decimal address 255 to 16383 and the higher 16K from 16384 to 32767).

That difference is pin 4 of RAM chips as this pin is the memory address line MA7. Pin 35 of the SAM chip steps directs signals to the RAM from the lower 16K to the upper 16K whenever a memory address from 16384 to 32767 is requested.

And there you have it... 32K!

## 14 - E SERIES 32/64K UPGRADE

For those of you with E series Color Computers (see chapter entitled "Taking a Look Inside" to determine which series computer your's is) this is the most cost-effective means of upgrading your machine.

The E series upgrade involves replacing the existing 4K chips (or if you've upgraded to 16K - the 16K chips) with 64K dynamic RAM chips. This installation does not require that you make the intermediate upgrade to 16K as is necessary with the piggyback or RAMCHARGER upgrades as described in the previous chapter.

As you read in earlier chapters, one of the predominant differences between the A through D series and the E series Color Computer is the number of jumpers installed on the printed circuit board. These jumpers program the SAM chip for the size and type of RAM chips that have been installed. Having only two jumper positions the stock A through D series Color Computer is only able to recognize 4K or 16K chips, and is not able to utilize the new 64K RAM chips.

While it is true that A through D series Color Computers can be hard wired to accept these larger chips, this is a fairly complex and possibly risky operation. It involves cutting of P.C. traces and some fine soldering, outside the realm of most of our capabilities, and somewhat beyond the scope of this book. Computers modified in this fashion will be denied servicing by Radio Shack Computer Repair Centres as well, compounding the problem.

In some cases Radio Shack Computer Repair Centres have been known to upgrade computers from D to E series, for a minimal charge, either by replacing or hard wiring the circuit board to the new configuration and allowing the owner to install his or her own 64K chips. A change of the Color BASIC ROM to version 1.1 is also required, as version 1.0 is incapable of dealing with the large chips.

Thus, this 32/64K upgrade is limited solely to E or later series Color Computers (or earlier series computers modified as described above).

Before we get started, however, a word or two is in order about the Radio Shack 32K upgrade.

The way the Color Computer is currently configured, only 32K of memory can be addressed at any one time. That is because the memory map only allows RAM to be located between addresses 255 to 32767 (however there is a way around this as described at the end of this chapter). The area above 32677 is used by the Color and Extended BASIC ROMs.

As there are no 32K RAM chips on the market, Radio Shack reached an agreement with Motorola to purchase their reject 64K RAM chips (with a defect of some sort in one of the two banks of 32K) at a considerable savings from cost of good 64K chips. These so called "half good" 64K chips form the basis of Radio Shack's 32K upgrade - with either the upper or lower 32K of memory permanently enabled (by connecting the appropriate jumper).

It is rumored that Radio Shack has an F series Color Computer with a 1.2 version of Color BASIC in the planning stages. This computer will recognize and be able to access a full 64K of user RAM.

As it is virtually impossible for ordinary mortals like you and me to purchase the "half good" 64K RAM chips, this upgrade is accomplished by using "all good" chips and then selecting one bank or the other of 32K. However, all is not lost as the end of this chapter will reveal how to access that other 32K (which can't be done with the Radio Shack "half good" chips).

#### PERFORMING THE 32/64K UPGRADE

-----

Purchase a set of eight 64K x 1 bit dynamic RAM chips (Texas Instruments 4164-15NLs, Motorola MCM6665s or equivalent).

You will also need a small ferrite bead and two 2-pin jumper blocks (or modified DIP jumpers -- cut into two sets of 2 pin connectors -- this is available as a complete kit from Disk 'n Data).

You will need the following tools for this upgrade: a Phillips screwdriver, sharp knife or razor blade, chip extractor or nailfile or small jeweller's screwdriver, pair of small diagonal cutters or heavy scissors, and a pair of needlenose pliers.

Okay, you're ready to start...

Make sure your Color Computer's power switch is turned off and the power cord is unplugged. Open up your Color Computer as described in steps 1 - 4 of the previous chapter (Taking a Look Inside).

# JUMPERS FOR THE E-SERIES 32K UPGRADE

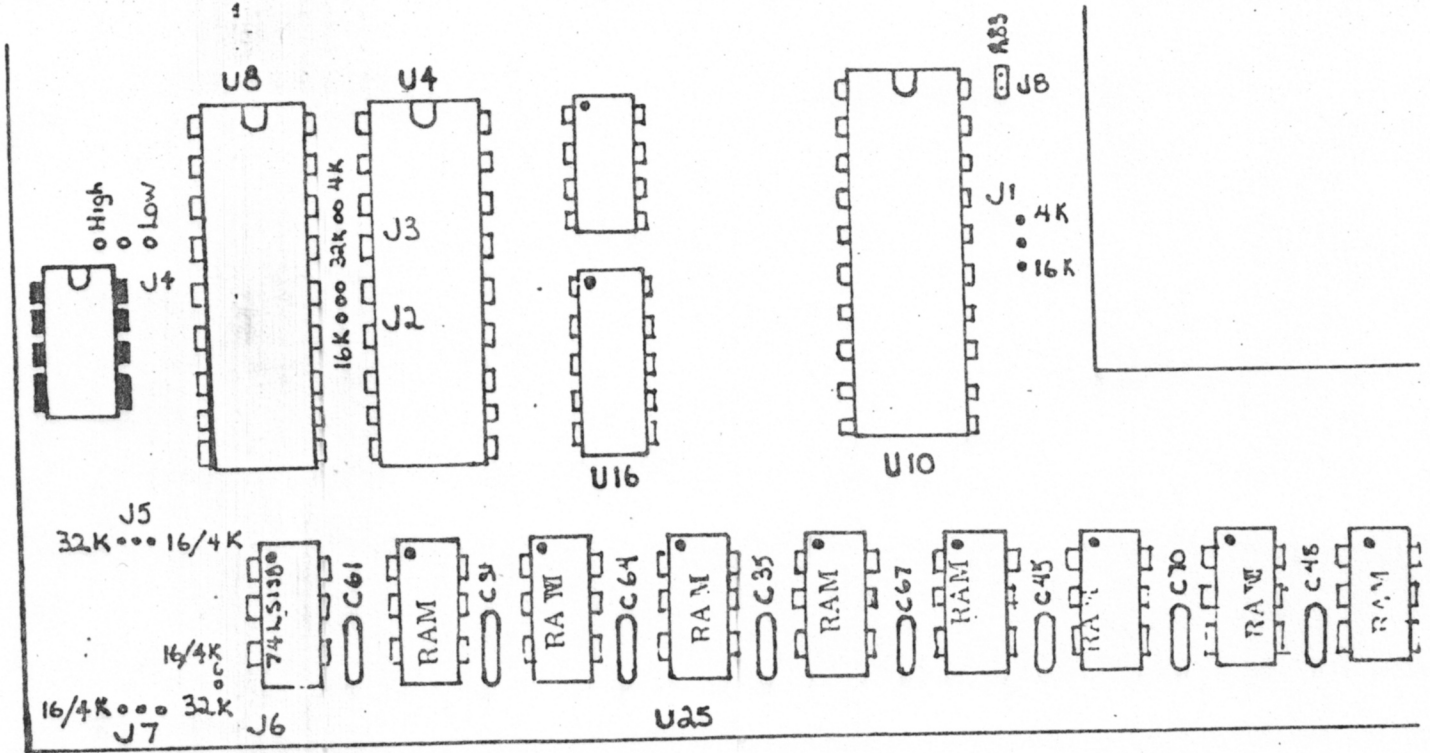
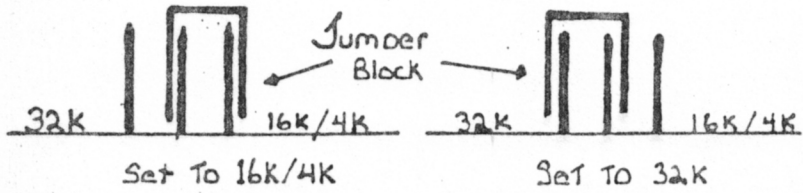

Remove the R.F. shield as described in step 4 (using the knife or razor blade to cut the shipping straps if you haven't done this before).

Under the R.F. shield locate the eight small chips located immediately above the keyboard, to the right. They are labelled from right to left U21 through U27 (these numbers are etched in green right in the printed circuit board). These are your 4K (or 16K) RAM chips (the ninth chip in that row, labelled U11, is not a memory chip).

Chips U21 through U27 must be carefully removed, one at a time. Notice the little notch (or the white dot) cut into the top of each chip? These are the index marks and indicate the polarity of the pins. Take note of which way the old chips are oriented as the new 64K chips must be inserted with the notch pointing in the same direction (the notch should be towards the back of the computer).

In order to extract the old chips, use your chip extractor to securely grasp and pull out each chip. If you do not have an extractor tool then use a small nail file or jeweller's screw driver and insert it under each 4K (or 16K) RAM chip in turn, pry it up slightly, rock it slowly from end to end, and lift it out of the socket.

Eight capacitors must now be cut from the printed circuit board.

They are the capacitors located between the RAM chip sockets from which you just removed your 4K (or 16K) chips. From left to right they are identified on the board as capacitors C61, C31, C64, C35, C67, C45, C70 and C48.

Using your diagonal cutters or a heavy pair of scissors carefully snip the top and bottom leads of capacitor C61 and remove it from the board. Do the same to the other seven capacitors - C31, C64, C35, C67, C45, C70 and C48.

Locate the jumper posts (J8 - see illustration) at the top right hand corner of the SAM chip (labelled U10), right near the resistor marked R83. Place the ferrite bead over one of the posts and connect the two posts together using one of your jumper blocks (or by wire wrapping them together). It's easiest if you use a pair of needlenose pliers to install the jumper blocks.

Next find jumpers J5, J6 and J7 on the board (see illustration). Jumper J5 is located immediately above and to the right of the 74LS138 chip (U11). Jumpers J6 and J7 are below J5. In each case remove the jumper block and place it on the two pins nearest the 32K designator which is etched in the printed circuit board (see illustration).

Now pinpoint jumpers J2 and J3 (between the U8 and U4 chips). If you are upgrading a 4K machine remove the jumper block at

Jumper J3 and position it in the 32K position at J2. If you are upgrading a machine which contained 16K chips, just move the jumper block at the 16K position of J2 to the 32K position of J2.

Finally, at jumper position J4 (to the left of chip U8) place a jumper block over (or wire wrap together) the post marked "LOW" with the centre (unmarked) post. This is the bank selector jumper which allows the SAM to address either the top or the bottom 32K of the 64K RAMs.

You are now ready to install your 64K chips. Carefully slide one of the new 64K chips from one of the ends of the static resistant shipping tube. Place it carefully in one of the sockets from which you removed your old 4K (or 16K) chips (you may have to bend the pins in slightly in order to ensure a good fit). Make sure that all the pins fit into their respective sockets, and that none of the pins are folded up under the chip.

Do the same for each of the other seven 64K chips. Ensure that the index marks are oriented in the proper direction (should be pointing towards the rear of the computer).

At last, -- that's it!

Before you test it out, make certain that you have correctly positioned the jumpers as outlined earlier. If any one of the jumpers is not in the right position, the 64K chips may be damaged. Also check to see that the 64K chips are all correctly inserted, oriented in the proper direction, and that no pin has slipped outside its socket, or has been bent up underneath the chip.

Make sure that all of your tools are out of the way. Plug in the computer, and power up; you don't need to replace the cover for this test--but be sure to keep your hands out of the works!

The screen will clear, but the Color BASIC message will take a little longer to appear than you're normally used to. Type in PRINT MEM, and you should have better than 31,015 bytes of RAM available with Color BASIC installed (24,871 bytes in an Extended BASIC machine or 22,823 bytes in a Disk BASIC machine).

#### WHAT COULD GO WRONG

-----

Problems will show up as a "locked up" machine with no sign on message, less memory than indicated above after a PRINT MEM statement, or random crashing.

"locked up" machine indicates RAM chips inserted backwards (notch on the wrong end), pins crushed underneath or outside the sockets, or (least likely) one or more bad memory chips. Recheck your work - and make sure all jumpers are in their proper positions.

If the proper amount of memory is not reported after a PRINT MEM, then the jumpers are probably not properly set. Too little memory might also point to a bad memory chip. Power up a few times and see if the PRINT MEM value changes each time. If that is the case it is possible that one chip is functioning too slowly and needs to be replaced.

Random crashing most likely indicates one or several chips not fully inserted in their sockets.

### ACCESSING THE OTHER 32K

As was mentioned at the outset, only 32K can be directly accessed by the Color Computer in its current configuration. However, you can access the full 64K if you disable the ROMs which occupy the area above decimal address 32767.

This can be accomplished through hardware by using one of the unused NOR gates (on chip U29) which exist on the Color Computer.

In order to do this you need to connect the appropriate pins of the 74LS138 Decoder chip (U11) to the 74LS02 Quad NOR gate chip (U29).

However, this upper 32K of RAM is useable only if you have another operating language (such as FLEX-9 available from Frank Hogg Laboratories) available, as the BASIC ROMs are disabled when it is accessed.

This modification requires some soldering experience to accomplish. If you feel capable, read on -- otherwise go to the end of this chapter ("Completing the Job") and close the computer back up.

### THE 64K MODIFICATION

For this modification you will need a soldering iron (25 watts or less), and some light-gauge (around 30-gauge or so) insulated copper wire, in addition to the tools mentioned above for the 32K upgrade.

Remove the 74LS138 Decoder chip (U11) and the 74LS02 Quad NOR gate chip (U29). Using your needlenose pliers, bend pins 4, 5

*Frank Hogg*



and 6 of the 74LS02 up until they are pointing straight up in the air. Do the same to pin 5 of the 74LS138.

Next, solder a short length of wire between pin 6 and pin 8 of the 74LS02 (note -- pin 8 is not to be bent up -- it must be plugged back in). Solder another length of wire so it joins pin 4 of the 74LS02 to pin 5 of the 74LS138. Then solder a 10-inch length of wire to pin 5 of the 74LS02.

Reinstall the chips in their original sockets, making sure the index marks are properly oriented. Make sure that pins 4, 5 and 6 of the 74LS02 (which are pointing up in the air) do not touch the edge of the R.F. shield.

Finally, connect the other end of the 10-in. length of wire to Test Point 1 (TP1) in the top upper right hand corner of the computer (see illustration). This connection can be made using a spare jumper block, or by wire wrapping or soldering.

Check carefully for shorts, cold solder joints, correct insertion of the chips, etc. If all is okay, plug in the power cord and do a PRINT MEM. It should give the same value as before (31+K for Color BASIC, etc. -- see above).

However, now when you write to an address above 32,767 the BASIC ROMs will be disabled. If you load a language such as Flex, it will then occupy the area above address 32,767, (at hex &HC000 to &HFFFF) taking the place of Disk, Color and Extended BASIC (as well as the area reserved for ROMPAKs). Utility programs can be located above Flex (between hex &HE000 to &HFFEF) The lower 32K RAM is available for user programs as always.

Note -- This 64K modification will not work with the "half good" Radio Shack chips, and may not work with all brands of 64K dynamic RAM chips (it will work with the Texas Instruments 4164s).

#### COMPLETING THE JOB

-----

If all is well, remove the line cord. Remember, because the computer's power supply is inside the case, it's always "live" when the power cord is still plugged in!

Before you reassemble everything, you might want to take this opportunity to install the Extended BASIC ROM chip. It goes in the empty socket (U28) at near the rear panel of the computer. You can purchase the Extended BASIC ROM in-kit from a Radio Shack Computer Repair Centre (the kit contains the chip and a manual) and install it yourself (you may have to fill out a waiver of warranty to obtain the kit) saving yourself the \$20-25 installation fee. All you do is plug the chip in the socket, and you're done!

Now replace the metal R.F. shield and follow the instructions for replacing the cover outlined in the previous chapter.

## 15 - CSAVING MACHINE LANGUAGE

At the outset, we stated that this book was for BASIC programmers -- not those looking for pointers on Assembly or machine language programming. However, in the course of using the Color Computer, most of us have acquired some machine language tapes.

As magnetic tapes are a fairly unstable medium (particularly for tapes that are used frequently) -- it is prudent to make backup copies of originals in case of accidental erasure, crimping of the tape, etc. This is easy to accomplish with BASIC programs, where just a simple CSAVE is required. However, machine language tapes are somewhat more difficult as exact start, end and transfer points are required.

Machine language tapes are saved to tape in the following format (note Extended BASIC is required to use the CSAVEM command):

```
CSAVEM"N",S,E,T
N=Title of the program (up to 8 characters)
S=Start Point
E=End Point
T=Transfer Point
```

The S, E and T points are easy to determine. Load in the machine language program you wish to make a backup copy of using the CLOADM command, but do not EXECute. Now instruct the computer to give you the following:

```
PRINT PEEK (487)*256 + PEEK (488)
PRINT PEEK (126)*256 + PEEK (127)-1
PRINT PEEK (157)*256 + PEEK (158)
```

The first value you get is the start point, the second value the end point, and the third value the transfer point (often the same as the start point).

Therefore, if you have a program by the name of TAPERREAD with a start point of 4000, an end point of 12000 and a transfer point of 5000 you can save it to tape in the following manner:

```
CSAVEM"TAPERREAD",4000,12000,5000
```

## 16 - SOME LAST PEEKS

Here is a summary of all the major PEEKS and POKES in this book -- and a few other odds and ends you might find some interesting uses for. All are grouped under the Color Computer component whose operation they alter.

COMMAND	ADDRESS	VALUE	EFFECT
<u>Color BASIC ROM</u>			
POKE	25,	6:NEW	Clears out the reserved graphics pages and allows maximum use of memory. Entered on power-up of the Computer, it will give you approx. 1.5K of additional memory.
POKE	25,	6	)Used together to clear out the reserved graphics area as above.
POKE	31,	6	
POKE	25,	PEEK(27)	)Used together to merge BASIC PEEK(28)-2) programs.
POKE	26,	PEEK(28)-2)	
POKE	25,	30	)Used after merging BASIC programs (see above).
POKE	26,	1	
PEEK	(27)		)This area stores the simple BASIC (non-array) variables.
-to- PEEK	(30)		

POKE	155,	N	Where N = any number from 1 to 255 sets the number of columns wide your printer will print.
POKE	275,	N	Where N indicates where the start of your machine language subroutine is (MSB). This tells BASIC where to look for your USR subroutine (see Getting Started With Color BASIC, p. 268).
POKE	276,	N	Where N indicates the LSB (Least Significant Bit) for the above.
PEEK	(338)		)These three locations contain )the last key(s) pressed. See )section on memory map.
-to- PEEK	(345)		
POKE	359,	13	Changes the regular green Color Computer screen to red.
POKE	359,	126	Changes the red screen (above) back to green.
PEEK	(465 - 472)		Name of last program CSAVED.
PEEK	(474 - 481)		Name of last program CLOADed.
POKE	1024,	0-255	POKE a value into the video display of the Color Computer and it will appear on the screen. Occupies the area from decimal address 1024 (&H0400) to 1536 (&H05FF). See section on memory mapping for details.
-to- POKE	1536,	0-255	

#### Synchronous Address Multiplexer

POKE	65314,	8	After printing to the screen, this POKE will create red letters on a pink screen.
------	--------	---	---

POKE 65495, 0

The notorious speed-up POKE, this actually increases the refresh cycle of the RAM, allowing the microprocessor to operate more quickly. CAUTION -- WILL NOT WORK WITH ALL COLOR COMPUTERS. After this POKE is entered, the cursor will either flash at double its previous speed -- or the computer will hang up. See the section of this book explaining the speed-up POKES.

POKE 65494, Anything Returns the computer back to normal speed from the speed-up POKE (above).

POKE 65497, Anything Causes the clock in the SAM to run at double speed. However, video output and keyboard debounce are affected. See section on the speed-up POKES.

#### Peripheral Interface Adapters

---

POKE 65313, 8 Turns on cassette motor.

PEEK (65280) Checks to see whether a joystick button has been pressed. Returns a 256 or 127 if no button has been pressed. If right button has been pressed it will return a 126 or 254. If left joystick button has been pressed, it will return a 125 or 253.

PEEK (65314) Checks the PIA to check the status of your line printer. If it returns a 4 or a 6 then the printer is on line. If it returns a 5 or a 7 then it is off line.

## LINE WIDTH DRIVER

```
1 * THIS PROGRAM WILL SET THE WIDTH OF YOUR LINE PRINTER.
2 * TYPE IN THE PROGRAM AS WRITTEN AND <RUN>.
3 * ENTER THE ADDRESS YOU WISH PROGRAM TO BE STORED AT AFTER PROMPT.
4 * POKE 155 WITH THE NUMBER OF CHARACTERS PER LINE YOU WANT PLUS 1
5 * (I.E. FOR A 32 CHARACTER LINE TYPE POKE 155,33).
15 CLS
20 INPUT "START ADDRESS";S
25 FOR A=S TO S+55
30 READ P
35 POKE A,P
40 NEXT A
45 EXEC S
50 DATA 182,001,103,167,141,000,046,190,001,104,175,141,000,040
53 DATA 134,126,183
55 DATA 001,103,048,141,000,004,191,001,104,057,052,002,150,111
58 DATA 129,254,038,016,150
60 DATA 156,139,001,145,155,037,008,015,156,134,013,173,159,160
65 DATA 002,053,002,018,018,018
```

## PRINTER LINE DRIVER

```
1 * THIS PROGRAM WILL SEND A LINE FEED TO THE PRINTER
2 * AFTER EACH CARRIAGE RETURN. TYPE THE PROGRAM AS IT
3 * APPEARS BELOW AND RUN IT. THEN TYPE <NEW> TO CLEAR
4 * OUT THE BASIC PROGRAM. PROGRAM WILL REMAIN
5 * IN MEMORY UNTIL THE POWER IS TURNED OFF.
10 CLS
20 FOR A=1000 TO 1021
30 READ P
40 POKE A,P
50 NEXT A
60 POKE 1021,PEEK(359)
70 POKE 1022,PEEK(360)
80 POKE 1023,PEEK(361)
90 POKE 359,126
100 POKE 360,3
110 POKE 361,232
120 DATA 052,020,214,111,193,254,038,011,129,013,038,007
130 DATA 190,160,002,173,003,134,010,053,020,057
```